

INSTALLATION OF MINIATURE THREADED SERIES TRANSDUCERS

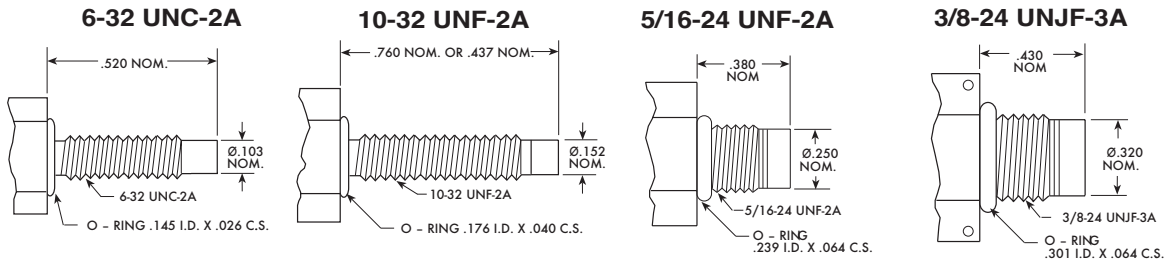

FIG. 1 (a)

FIG. 1 (b)

FIG. 1 (c)

FIG. 1 (e)

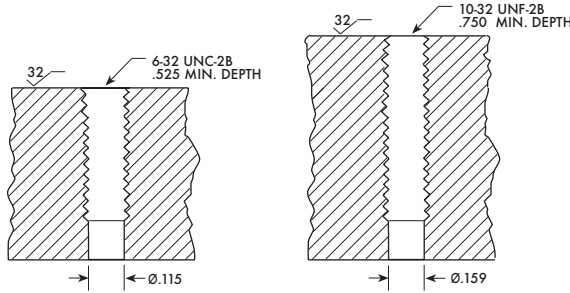

FIG. 2 (a)

FIG. 2 (b)

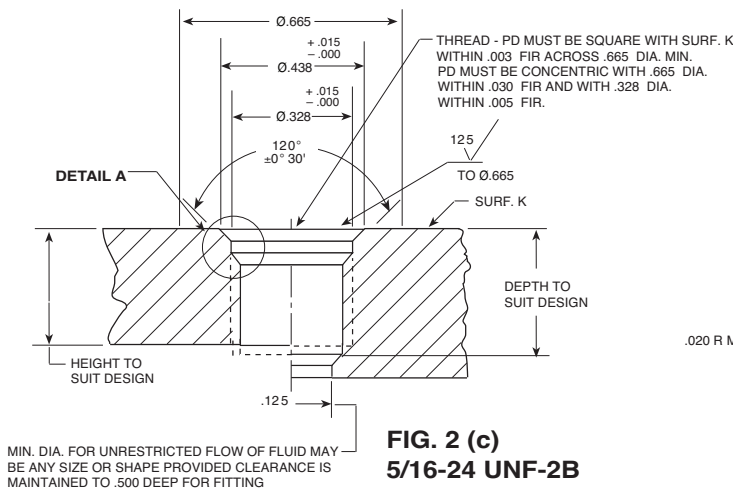

FIG. 2 (c)
5/16-24 UNF-2B

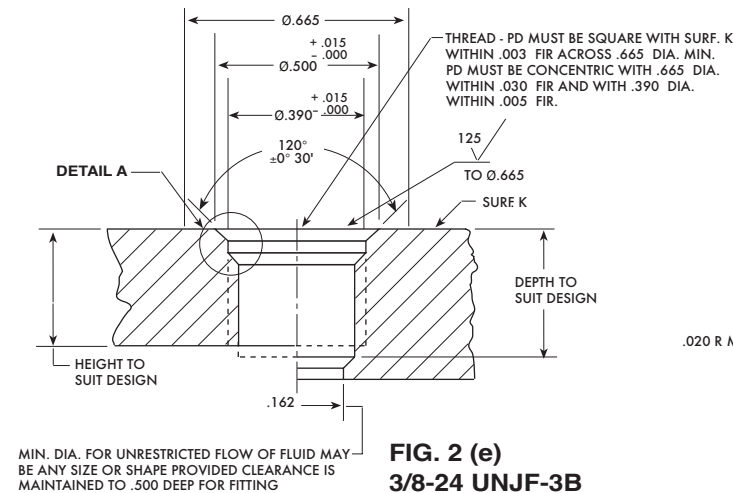
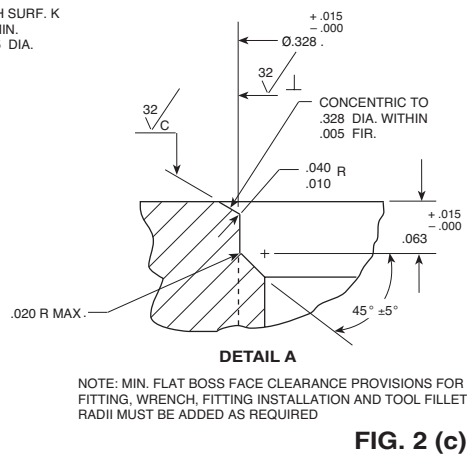
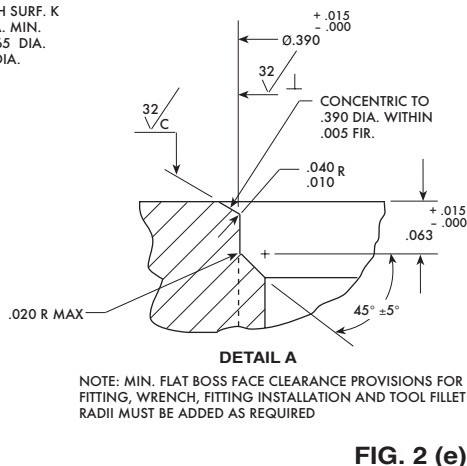

FIG. 2 (e)
3/8-24 UNJF-3B



For proper mounting of Figure 1 (e), an MS33649-3 port is required. The detail for this port is shown in Fig. 2 (e) and Fig. 2 (e) Detail. For convenience in machining, a contour cutter for MS33649 ports can be used to produce the required detail of the port and drill the pilot hole ready to be tapped. Mounting torque for the transducers is listed below.

| | | | | | |
|---|--|---|--|--|---|
| 6-32 UNC-2A 15 Inch Pounds (Max.) | 10-32 UNF-2A 15 Inch Pounds (Max.) | 1/4-28 UNF-2A 50 Inch Pounds (Max.) | 5/16-24 UNF-2A 75 Inch Pounds (Max.) | HKS-375 ONLY 3/8-24 UNF-3A 180 Inch Pounds | 3/8-24 UNJF-3A 80-120 Inch Pounds (M) |
|---|--|---|--|--|---|

INSTALLATION OF MINIATURE THREADED SERIES TRANSDUCERS

CRYOGENIC SERIES

CTL-190
10-32 UNF-2A

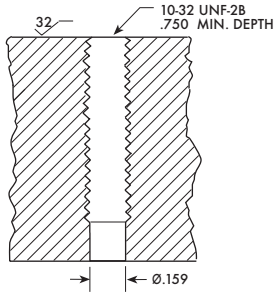
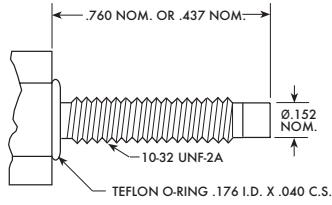

CTL-312
5/16-24 UNF-2A

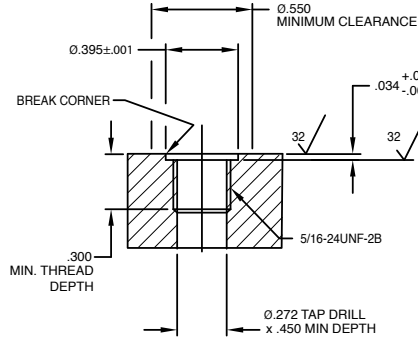
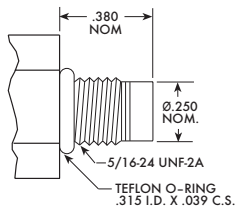

CTL-375
3/8-24 UNJF-3A

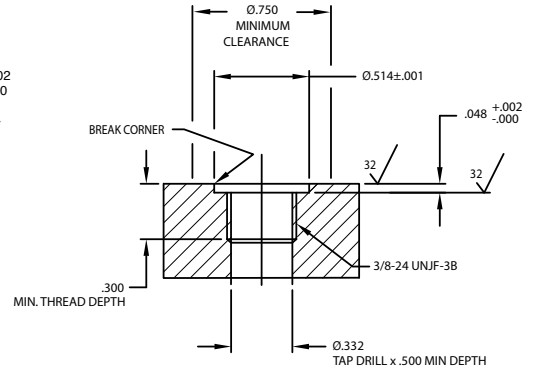
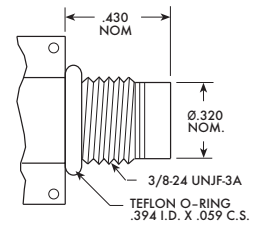

(E)WCT(V)-312

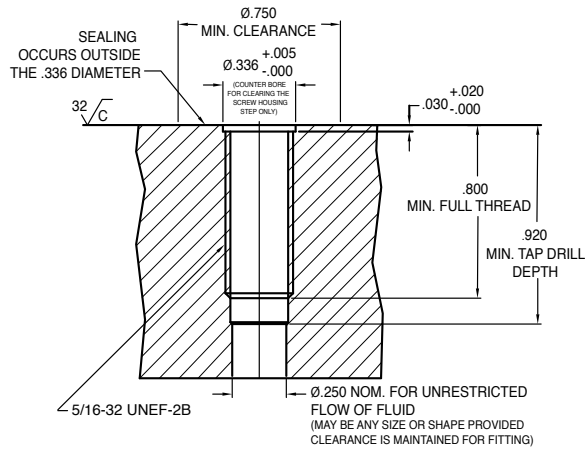
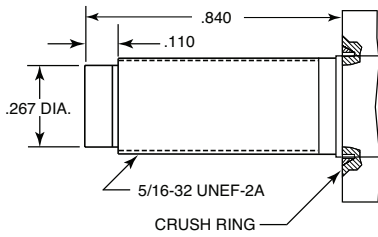

ETL-GTS-X-312

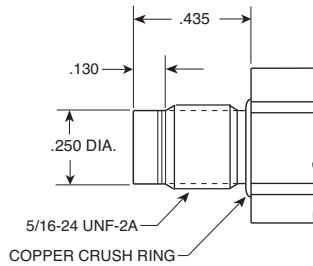

5/16-24 UNF-2B

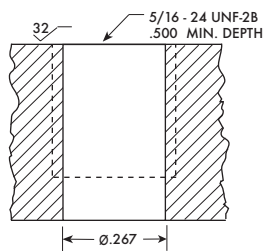

TTS-X-235

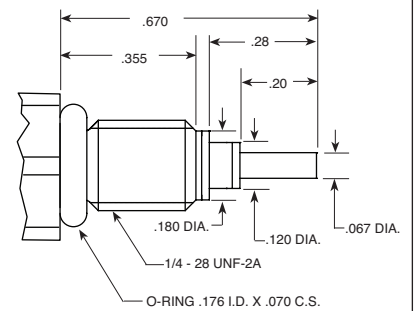

1/4-28 UNF-2B

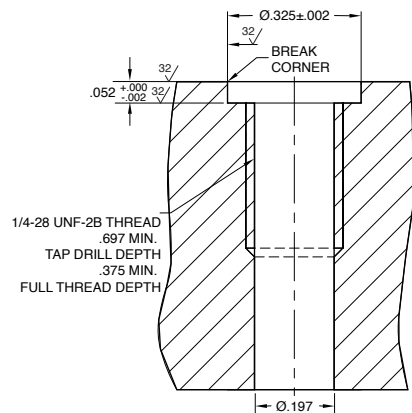

(M)

INSTALLATION OF MINIATURE THREADED SERIES TRANSDUCERS

KZS SERIES

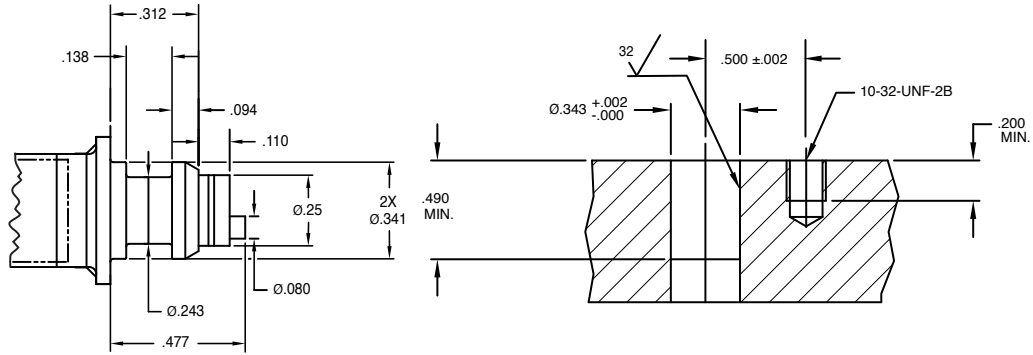

9/16 - 18 UNF-3A

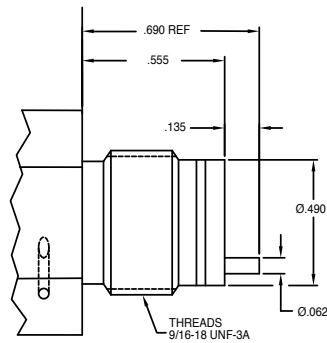

9/16 - 18 UNF-3B

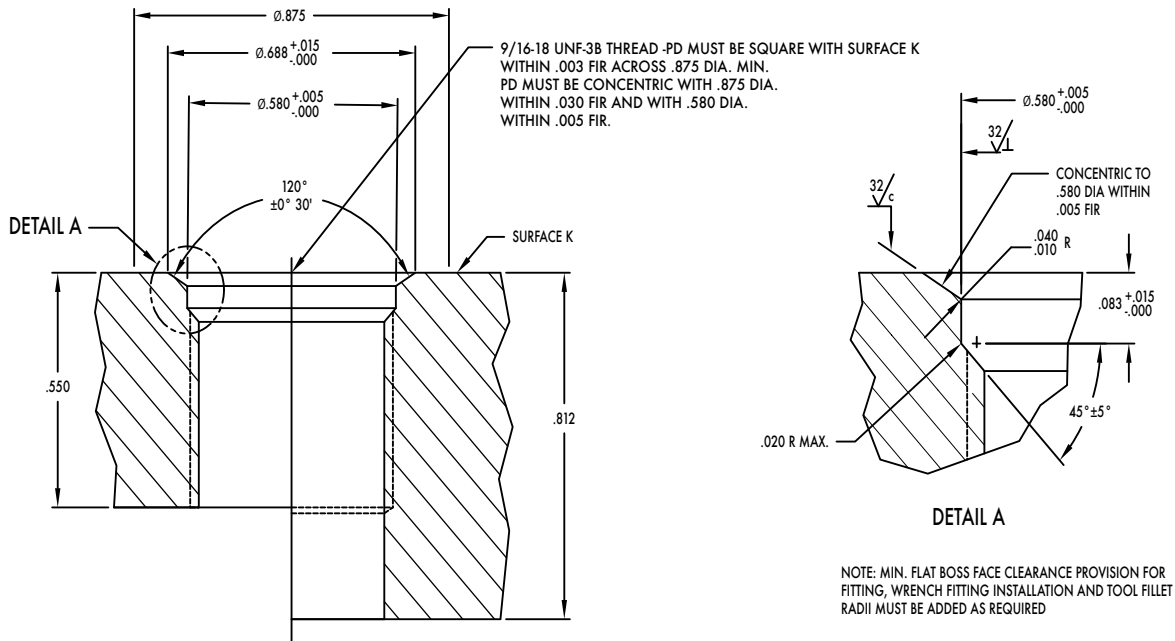

INSTALLATION OF MINIATURE THREADED SERIES TRANSDUCERS

ATS-42 & ATS-42HT SERIES

7/16 - 20 UNJF-3A

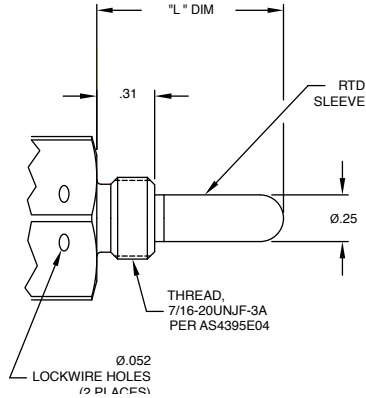

7/16 - 20 UNJF-3B

