

The importance of quality signal conditioning in the acquisition of high-quality dynamic pressure measurements is often underappreciated. While developing the test requirements, researchers and test engineers often focus all of their attention on the pressure transducer and data system specifications with little comprehension of the benefits provided by a stand-alone signal conditioner/amplifier (SCA) system. Frequently, the realization that data quality is suspect or unacceptable occurs too late during a test campaign for a straightforward resolution using available conditioning systems. The time to identify the need for stand-alone SCAs is in the test-planning phase. This application note will illustrate the benefits of stand-alone SCAs as a key component of dynamic pressure measurement systems and call attention to the shortcomings found in many “universal” data systems available on the market today.

Measurement quality suffers when a portion of the measurement chain is not capable of transmitting the high-frequency signal content of Silicon on Insulator (SOI) piezoresistive pressure transducers with minimal added noise. The bandwidth dependent signal-to-noise ratio, SNR, of a typical miniature Kulite pressure transducer installation exceeds 100 dB¹. This means that the full-scale pressure reading for a Kulite pressure transducer may exceed its intrinsic noise by 100,000x or higher. A fundamental role of a stand-alone signal conditioning/amplifier is transforming the output of high-impedance transducers to low-impedance voltage sources capable of low-noise, high-frequency transmission. Each SOI piezoresistive pressure transducer exhibits changes in resistance that are proportional to the applied pressure. The individual piezoresistive gages of an SOI pressure sensor are configured to form a fully active Wheatstone bridge. Applying voltage excitation converts the small changes in resistance (1% to 2% of the nominal level at the full-scale pressure) into easily configured voltage measurements.

The system block diagram shown below illustrates the stand-alone SCA in blue dashes.

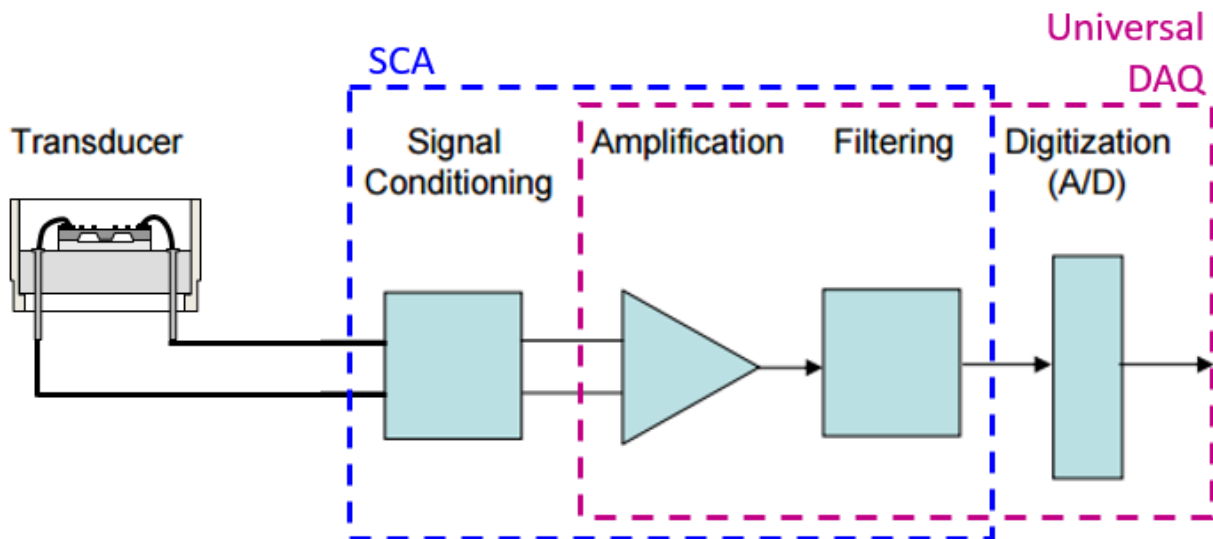

Figure 1: Pressure Measurement Signal Chain. Universal DAQ functionality-Purple. SCA functionality-Blue

The Importance of Quality Signal Conditioning for Pressure Measurements

The recent availability of “universal data acquisition systems” (Universal DAQ) from many data system providers has led to unrealistic data quality expectations. The advertised performance specifications with a notional transducer may suggest a measurement capability that easily meets the testing needs. Actually, the manufacturers of these data systems unknowingly constrain the testing organization into an unrealistic transducer design to maintain the advertised performance. The data system designers often have very limited knowledge of transducer construction, and particularly, an understanding of the typical electrical characteristics of an as-manufactured Wheatstone Bridge-based transducer.

The Universal DAQ designs followed the arrival of integrated function data converters. The purple dashed lines in Figure 1 illustrate the functions supported by these modern integrated circuits (ICs). The ICs usually incorporate a ratiometric voltage source for the sensor, a differential amplifier with programmable gain (PGA), a simple 1-pole analog filter, and a high-resolution single range A/D converter – typically a 24-bit sigma-delta design. This functionality offers considerable benefits when the system designer embeds a piezoresistive pressure sensor with the integrated circuit in a portable application such as a low-cost digital tire pressure gauge or a higher-end product such as a hand-held pressure calibrator. These ICs work best when the designer has full control over the measurement circuitry from the pressure sensor to the user interface and can minimize the zero offset and properly scale the input voltage to the digitizer.

Data system manufacturers have adapted the integrated function data converters for multi-channel input modules. A particular selling point made by the manufacturers is that they have eliminated some external instrumentation requirements, in particular, the stand-alone SCA. This new class of instrument trades product miniaturization and lower manufacturing costs for significant excitation, amplification, and anti-alias filtering limitations. In short, the measurement engineer is seriously constrained when using a Universal DAQ to interface directly to an SOI piezoresistive pressure transducer. Additionally, these modules are unsuitable for high frequency, time-domain analysis due to the internal sigma-delta A/D converter and its inherent digital filtering of the digitized signal.²

A common argument from data system manufacturers is that a 24-bit A/D converter has enough resolution to capture all useful content of a high-frequency dynamic pressure signal. Despite this assertion, inadequate signal resolution can easily compromise such an installation. The SNR of the IC used in the Universal DAQ is typically lower than the SNR exhibited by SOI piezoresistive pressure transducers. Inflexible gain and input voltage settings often mean that only a few percent of the transducer dynamic range are used to measure the full-scale pressure signal. As a result, signals look “digitized” or simply do not contain finer content. The Universal DAQ approach offers inherently less capability than a stand-alone bridge conditioner combined with a similarly capable A/D converter. Their “all-in-one” design results in a hardware interface that is often not suitable to meet testing objectives when used in conjunction with an SOI piezoresistive pressure transducer.

The list below provides the basic signal conditioning functions required for a typical SOI piezoresistive pressure transducer. This application note will give measurement engineers sufficient justification for the inclusion of stand-alone signal conditioners in dynamic pressure system installations from the outset. Where appropriate, shortcomings specific to Universal DAQ systems will be mentioned.

Signal Conditioner Functions

1. Provide **excitation** voltage/current
2. **Suppress** any zero measurand output signal
3. **Reject** extraneous noise
4. **Amplify** the low-level signal
5. Filter the signal before digitization (**anti-aliasing**)
6. Drive **transmission** cables

The Importance of Quality Signal Conditioning in Pressure Measurements

Transducer Excitation: A low-noise, constant voltage source normally powers a SOI piezoresistive pressure transducer. The thermal compensation circuitry and full-scale output (100 mV, typical) are determined during production at a specific excitation voltage, usually 10 VDC. The typical Kulite ratiometric sensitivity can be expressed as 10 mV/V, nominally 10 mV of output signal per volt of excitation. The current draw from the excitation source will range from about 4 mA to 10 mA. This level is dependent on the input impedance, R_{IN} , shown on the transducer calibration certificate, and to a lesser extent the resistance of the wiring added by the end user.

The low levels of current demanded by Kulite pressure transducers often tempt the end user into the installation of a single common excitation power supply for all transducers. This approach does work, but will always add noise to the dynamic pressure measurement and desensitize the transducers. Any wiring issues or failed transducers may affect the excitation delivered to the functional transducers. For any bridge-based transducer, noise riding on the excitation voltage will be passed to the output signal and input to the amplifier as a ratiometric noise source. The best lab-quality power supply will typically include a noise specification of no lower than 250 μ V rms wideband ripple on the output. That level, when present at frequencies higher than the common-mode rejection capability of the input amplifier, can yield no better than 80 dB of clean signal for 10 VDC line voltage over a 20 kHz bandwidth. The common excitation wiring, functioning as multiple antennas, may allow external noise to enter the measurement chain as well. Precautions must be taken to minimize the magnetic loop area of the excitation network by organizing the wiring such that the conductor spread is minimized.

The signal conditioner must provide a low-noise excitation voltage source set at the transducer's factory calibration level for best results, usually 10 VDC. Since the length of cable supplied with the transducer is usually no more than 1 meter, additional extension wiring/cablings is required in most installations. The factory-recommended excitation voltage should be monitored from the same location (1 m from the transducer) during operation for highest accuracy applications. An option for remote excitation sensing (4-wire Kelvin) with short-circuit and excitation runaway protection is recommended to continuously and automatically correct for voltage drops caused by lead wire resistance in the extension cables. A bridge transducer with four equal value gages outputs approximately 5 volts (referenced to ground) of "common mode" voltage (V_{CM}) with 10 VDC unipolar excitation. The external components used to maintain the nominal ratiometric sensitivity of 10 mV/V over the operating temperature will alter the voltage delivered to the bridge resulting in a reduction of V_{CM} to 2 – 4.5 volts in most installations.

Another common option for Wheatstone bridge measurements is balanced bipolar excitation, in which +5 VDC and -5 VDC are applied to the +In and -In leads. A bridge transducer with four equal value gages outputs approximately 0 volts (referenced to ground) of common-mode voltage with balanced bipolar excitation. This provides excellent noise immunity while increasing the potential for high-accuracy voltage measurements. This design is available in metal-foil gaged transducers and in some of the physically larger piezoresistive transducers where more internal volume is available for the placement of additional thermal compensation components. However, such a design is not typically employed inside the in-line compensation modules supplied with ruggedized miniature bridge transducers where size and environmental compatibility restrictions limit the inclusion of additional components required to support the zero-centered output. The available external compensation circuitry may shift V_{CM} to -3 volts for SOI transducers powered by 10 VDC balanced bipolar excitation.

The Importance of Quality Signal Conditioning for Pressure Measurements

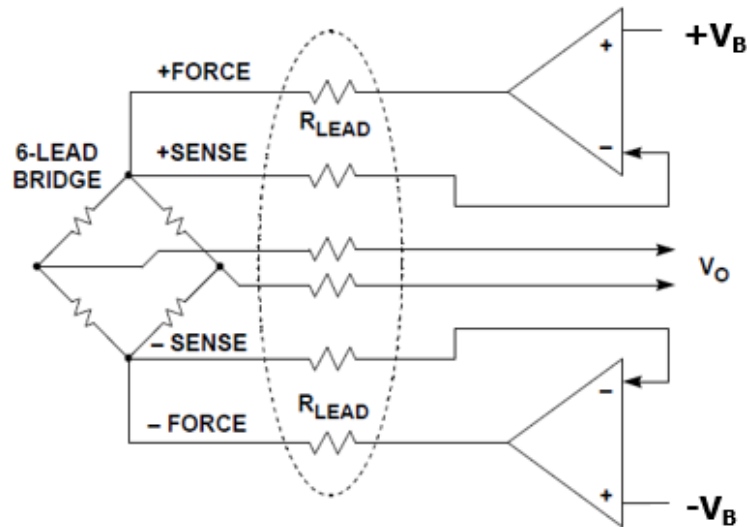

Figure 2: Balanced Bipolar 4-wire Kelvin Voltage Excitation

This lack of understanding on the part of Universal DAQ designers often forces the use of lower excitation levels and reduced amplification. Legacy data system designs supported common-mode voltages of ± 10 volts and higher, but that is not the case with integrated function data converters. Most Universal DAQ designs will not accept common-mode voltages outside the range of ± 2.0 volts.³ The SOI pressure transducer may appear to be functioning with 10 VDC applied, but the gain is limited as V_{CM} approaches either +2V or -2V. The excitation sourced to the miniature Kulite pressure transducers must be lowered to yield an acceptable PGA common-mode input range for some percentage of piezoresistive pressure transducers. The next available excitation level provided by these systems is often 5 VDC (+2.5 VDC and -2.5 VDC). This setting also halves the full-scale pressure output further increasing the measurement error. These two common Universal DAQ shortfalls combined with the omission of bridge suppression electronics can significantly reduce the full-scale output signal levels transmitted to the digitizer.

Signal Suppression: A stand-alone SCA will allow the end user to control the zero offset level of the signal. Predetermined levels for zero pressure values or the removal of any residual offset are necessary for two reasons. The first is that a zero pressure reading common to all transducers offers a very quick means to identify any failed input, no matter which component is suspect. The second and more important aspect of suppression is the ability to remove a DC offset prior to amplification. Suppression used to approximate a known pressure, i.e., suppression to local atmospheric pressure or to a specific voltage level is known as “live offset.” Ideally, the adjustment range should be reasonably large, but offer fine offset control so that a relatively low signal level may be set as the live offset. This permits the end user to achieve a maximum resolution measurement of the dynamic pressure signal as the amplifier gain is not constrained by the presence of a large, fixed offset voltage. Universal DAQs offer a software-based suppression where the residual offset of the transducer is stored as a dynamic variable. This approach permits the inclusion of a live offset, but does not increase the dynamic headroom of the input.

It is very important that the SCA perform the signal suppression without affecting the equivalent circuit of the SOI piezoresistive pressure transducer including the thermal compensation network. A high-quality differential amplifier typically buffers the input signal prior to the suppression circuitry. This technique prevents the suppression adjustments from altering the thermal compensation or sensitivity characteristics of the transducer. Some legacy SCA designs include potentiometers that inject current into

The Importance of Quality Signal Conditioning for Pressure Measurements

the transducer bridge arms to suppress the offset. Avoid these designs for all SOI piezoresistive pressure transducer installations as the potentiometers invalidate the transducer calibration and can significantly affect the thermal stability.

Noise Rejection: A quality stand-alone SCA includes electronics to reject out-of-band radio frequency and electromagnetic interference, RFI/EMI. Uncontrolled RFI/EMI will enter the circuitry and has the potential to saturate the amplifier. Amplifiers exhibit a specific recovery time for impulses. This recovery time is normally different for positive and negative impulses. Low-pass filtering of an amplifier that has been exposed to a high level of RFI/EMI will result in an unstable DC offset due to internal signal rectification.⁴

A high-pressure SOI piezoresistive pressure transducer could have resonant frequencies above 1 MHz. These high levels of sensor ringing during blast and shock pressure measurements are usually far outside the frequencies of interest. The simple approach to eliminate EMI/RFI noise potential or accidentally overloading the amplifier due to sensor resonance is the application of a differential low-pass filter ahead of the amplifier using a carefully designed passive network of resistors and capacitors. The classic EMI/RFI filter representation⁵ is shown in Figure 3. The filter frequency should be low enough to attenuate the EMI/RFI signal between the differential input lines to a tolerable level, but high enough that it minimally attenuates the incoming dynamic pressure signal. The filter also has to preserve the common-mode rejection of the amplifier while minimizing the addition of thermal (resistor) noise to the signal.

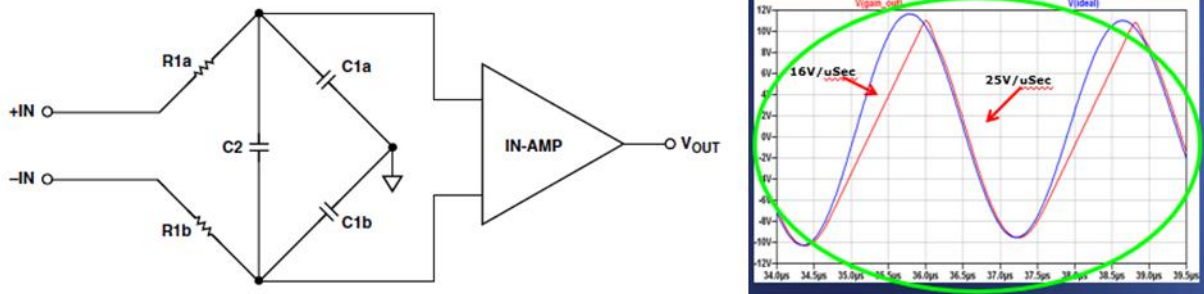

Figure 3: Low Pass Filter for the Prevention of RFI or Resonance Rectification Errors

Amplification: This primary function of an SCA involves the removal of any DC signal common to both input leads (average of the voltage on both input leads) and the amplification of the low-level differential voltage containing the dynamic pressure content. The common-mode rejection ratio (CMRR) of the input amplifier is the ratio of the differential-mode gain to the common-mode gain. This performance specification, expressed in dB, provides an indication of how well the amplifier measures low-level signals in the presence of voltages common to both input leads. An SOI piezoresistive pressure transducer should never be measured with a single-ended or pseudo-differential amplifier.

As previously discussed, the design of the pressure transducer can result in 3 volts or more of common-mode voltage. Kulite recommends that research and test personnel specify an SCA with common-mode input range of at least ± 10 Vpk with a CMRR of 90 dB to keep the differential voltage measurement errors at reasonable levels. See Equation 1 below for an estimate of the voltage measurement error⁶ along with the importance of minimizing V_{CM} and maximizing CMRR.

$$\text{Equation 1: } V_{ERROR} = \frac{V_{CM}}{10^{\left(\frac{CMRR}{20}\right)}}$$

The Importance of Quality Signal Conditioning for Pressure Measurements

Another key feature of a quality stand-alone SCA is programmable gain to maximize the resolution of the measured signal by matching the amplifier output to the A/D converter input range. This capability is key to enable the testing organization to obtain the full benefit of modern, high-resolution A/D converters. Highest-quality SCAs employ multiple stages of gain. It naturally follows that CMRR improves with increasing gain at the input stage. Therefore, the end user should always apply the highest safe gain in the 1st stage to maximize CMRR and minimize non-intrinsic noise amplification in subsequent gain stages. Universal DAQs are typically supplied with one amplification stage having a binary gain sequence.

The continuous and/or latching overload detection feature found on some high-end SCAs offers some protection against the long-term collection of erroneous data. This feature allows the end user to maximize the 1st-stage gain without the anxiety of unknowingly overdriving the internal amplifier circuitry or output to the A/D converter. Another feature of some programmable SCAs is high-resolution, vernier gain in the output stage to enable the same sensitivity of all pressure transducers as referred to the output. For example, all transducers adjusted to provide 500 mV of signal per PSI will support a ± 20 PSI full scale input to a ± 10 volt A/D converter. This feature can simplify data reduction and all but eliminate the bookkeeping of calibration constants in the test database. Finally, Kulite recommends that research and test personnel specify an overall linearity/calibration uncertainty and zero stability of the SCA to be at least 4X better than that required of the transducer for best results.

Anti-Alias Filtering: The basic function of the low-pass filter contained in an SCA is to minimize the effects of aliasing on digitized pressure data. Aliasing occurs when the low-pass filter does not effectively attenuate frequencies above half the A/D sample rate known as the Nyquist frequency. It is impossible to distinguish these aliased signals from the steady state and dynamic pressure content within the frequency range of interest. The optimum low-pass frequency setting providing -3 dB attenuation, i.e., corner frequency, would depend on a number of factors not limited to the filter order, filter type, sampling frequency, out-of-band pressure response, any resonances, A/D converter architecture, and required flatness in the filter passband. Sampling theory and the various analog filter topologies are beyond the scope of this application note. However, common linear-phase and maximally flat filter properties are presented.

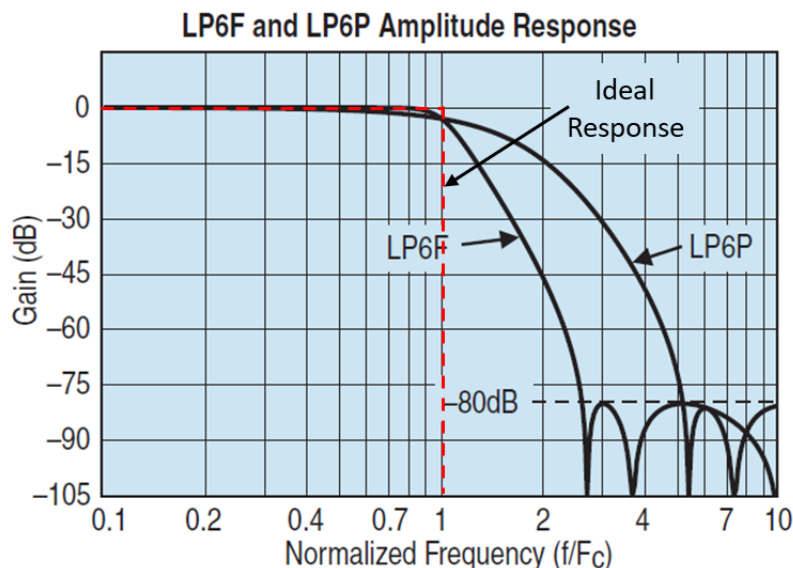

Figure 4: Perfect “Brick Wall” Filter with Linear Phase LP6P and Maximally Flat LP6F Magnitude Plots

The Importance of Quality Signal Conditioning for Pressure Measurements

An ideal filter response would not attenuate the signal within the frequencies of interest while it eliminated all frequencies outside the range of interest. An ideal filter would also pass all frequencies with the same time delay. These perfect “brick wall” filters do not exist in practical analog representations. Most low-pass filters supplied with stand-alone SCAs offer the Bessel response or the Butterworth response. Filters typically exhibit a 2-pole or 4-pole response, but 6-pole and 8-pole versions are available in high-end SCAs. Figure 4 shows the 6-pole filter response available with the Kulite KSC-2 signal conditioner.

The Bessel response offers a linear-phase response within the passband, at the cost of some attenuation of the desired signal. Transition to the stopband where incoming frequencies are effectively attenuated is typically slow. Linear phase filters such as Bessel are best for spectrally rich measurements such as transient blast and shock events due to the minimal distortion of the filtered signal content. These filters provide a reasonably faithful response to a step input pressure as shown in Figure 5 below. Generally, the linear-phase filter is preferred for time domain measurements and analysis.

The Butterworth response remains flat for most of the passband region, but offers a linear-phase response to less than half the corner frequency. Consequently, a maximally flat filter response such as Butterworth will overshoot and ring when subjected to a step input pressure. The filter transition to the stopband occurs at reasonably low multiples of the corner frequency effectively lowering the required A/D sampling frequency and data storage requirements. For these reasons, the maximally flat filter is preferred for frequency domain analysis and measurement of test articles subject to steady state conditions.

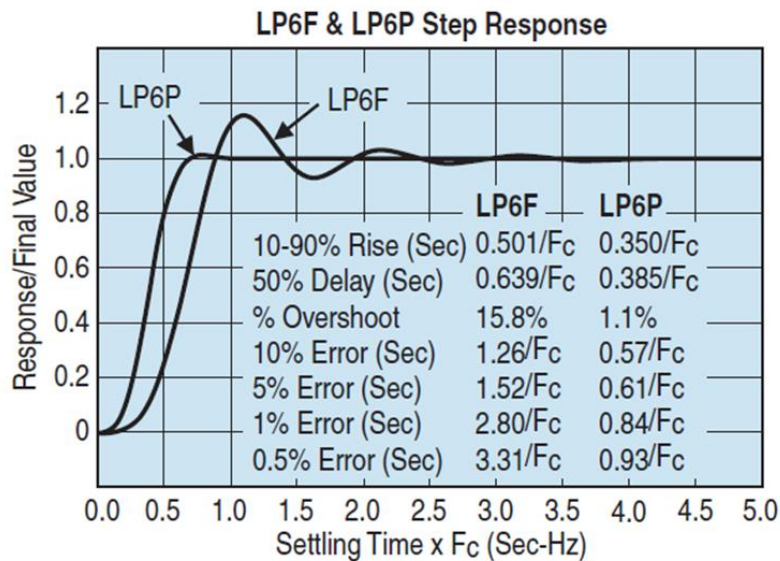

Figure 5: Linear Phase LP6P and Maximally Flat LP6F Step Response Plots

Properly designed amplification circuits maintain desired bandwidth for all full-scale input voltage ranges and will not attenuate the amplified signal at higher gains with increasing frequencies. Some high-end SCAs also incorporate a wideband filter response to 100 kHz and higher for transmission of high-frequency pressure information to an appropriate high-frequency instrument such as an oscilloscope or spectrum analyzer. The full-scale output voltage may be subject to buffer amplifier slew rate limitations at the frequencies above 100 kHz.

The Importance of Quality Signal Conditioning for Pressure Measurements

Placing the low-pass filter between the 1st-stage of amplification and 2nd-stage of amplification minimizes out-of-band energy such as transducer resonant peaking that may otherwise overdrive the amplifier. This amplifier/filter placement recommended by Kulite is known as distributed gain. This design is especially important in pressure shock, blast testing, and supersonic/hypersonic wind tunnel testing where the transducer resonant frequency will be driven by the input, and often produce signals far larger than those contained within the frequencies of interest. Distributed gain enables the researcher and test engineer to effectively filter the resonance and maximize the sensitivity settings when properly configured.

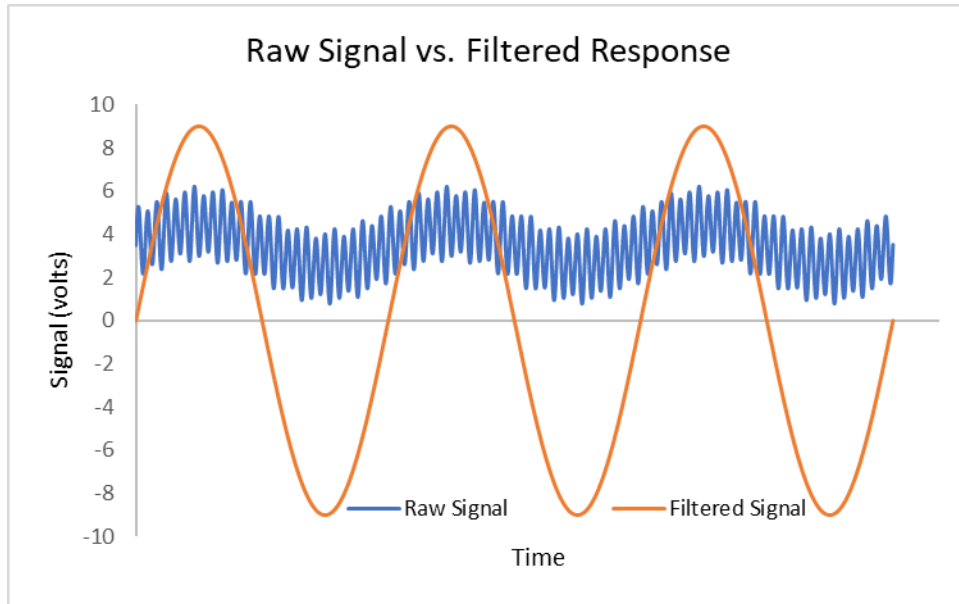

Figure 6: Improved Signal Using AC Coupling and Anti-Alias Filters

Another feature of many SCAs is a selectable front-end high-pass filter network designed to pass or block steady state pressure content. This AC/DC coupling network supports the capability to perform an in-situ calibration by loading discrete pressure steps when DC coupled. Then, the researcher is able to zoom in on small-scale dynamic pressures when AC coupled. Removal of the unneeded DC signal ensures that the amplifier headroom is not artificially limited. When describing the frequency response of an SCA, one must include the AC-coupled high pass corner frequency in the frequency range, i.e., 0.25 Hz to 125 kHz. Figure 6 shows the treatment a low-level signal having a significant voltage offset eliminated via AC coupling and the removal of out of band energy using an anti-alias filter prior to 2nd stage amplification.

Signal Transmission: The ability to amplify and transmit signal content to high frequencies with minimal noise is often the primary justification for stand-alone signal conditioning. As mentioned above, an SCA transforms the transducer output into a low-impedance voltage signal. This serves to both minimize noise coupling and alleviate the limitations presented by excessive cable capacitance.

Universal DAQS are modular and compact designs suitable for placement close to the sensors. Locating the data acquisition system near the sensors may save wiring costs, but will result in larger measurement error due to thermal drift. Remotely locating the sensitive data acquisition system in an environmentally controlled area will provide the lowest measurement error. With a stand-alone SCA, the test engineer has added flexibility in the placement of the SCA and data acquisition system. The stand-alone SCA placed close to the sensors improves signal quality while controlling the DAQ environment minimizes error.

The Importance of Quality Signal Conditioning for Pressure Measurements

Each SOI piezoresistive pressure transducer is a resistive-based device exhibiting a typical output resistance of 1000 ohms and higher. The addition of 200 feet of cabling to the transducer will typically limit the frequency response of the pressure signal to 25 kHz and lower due to the RC circuit behavior of the output resistance working against the cable capacitance. A typical SCA has an output impedance of 10 ohms. Placement of the SCA close to the pressure transducer will therefore reduce the resistance working into the cable capacitance by one to two orders of magnitude. The reduction in source impedance is inversely proportional to the corner frequency increase exhibited by the transmitted signal.

The reduction in source impedance is also directly proportional to the EMI/RFI noise coupled into the cable. Combining the lower noise levels with increased signal levels (amplified by 100 or more) helps to maintain a high SNR up to the A/D input. Transforming the source impedance to low levels also permits the use of general-purpose, 2-conductor cabling between the SCA and measurement system. This cabling is available at a fraction of the 6-conductor low-capacitance, instrument-grade cabling cost. The placement of the SCA is often the primary design consideration when high frequency content is required because it represents the most cost-effective means of increasing the system frequency response and reducing the effects of RFI/EMI on the signal.

Conclusion

Kulite recommends the inclusion of dedicated signal conditioning in all dynamic pressure data systems to preserve the signal resolution provided by SOI piezoresistive pressure transducer. This architecture provides decades of service, adaptability, expandability, and most importantly, the successful delivery of high-quality analog content to any interconnected data acquisition system. A modular data system design using programmable signal conditioning/amplifier systems gives the testing organization the flexibility to adapt many styles of sensors and transducers to the data acquisition system. Additionally, this approach allows the testing organization to adapt the data acquisition system to meet varying test requirements and upgrade A/D measurement systems to the most advanced technology of the day independently of the signal conditioning equipment.

References

¹ "Best Practices for Reducing Pressure Measurement Noise, Part 1: Electronics," Kulite Semiconductor Products Technical Document TD-1013, 2021

² "SAR ADCs vs. Delta-Sigma ADCs: Different Architectures for Different Needs," TI Training webinar with Anthony Vaughan and Ryan Calloway, Oct. 2015

³ "PGA Common-Mode Voltage Limitation," TI Presentation prepared by Joachim Wurker, October 2014

⁴ Al Szary and Doug Firth, "Signal Conditioning Perspectives on Pyroshock Measurement Systems," Sound & Vibration, 2013

⁵ Charles Kitchin, et. al, "AN-671 Application Note: Reducing RFI Rectification Errors in In-Amp Circuits," Analog Devices 2003

⁶ John Gyorki, "Strain Sensor Basics and Signal Conditioning Tips," Sensors Magazine, June 1, 2005