

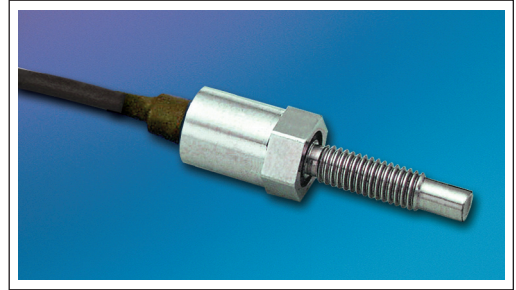

MOISTURE RESISTANT HIGH INTENSITY MICROPHONE

MIC-4-190 SERIES

- Low G Sensitivity
- Small Size
- Flat Response
- Wide Dynamic Range
- High Static Pressure
- Steady State Response Capability
- Silicon on Silicon Integrated Sensor **VIS®**
- Moisture Resistant



The Kulite MIC Series is designed for the measurement of sound pressure where conventional microphones cannot operate due to elevated dynamic pressure, high static pressure, excessive moisture or high temperature. Acoustic pressures over the dynamic range 95 to 185 dba can be measured. The sensor is extremely rugged and does not require additional protection except when used in flows containing particles (i.e. wind tunnels, engine test cells, etc.). "B" Screens are supplied standard on all Kulite microphones. "M" Screens or No Screens are optional.

Kulite recommends the [KSC Series](#) of signal conditioners and [LPF reference filters](#) to maximize the measurement capability of the MIC Series transducers.

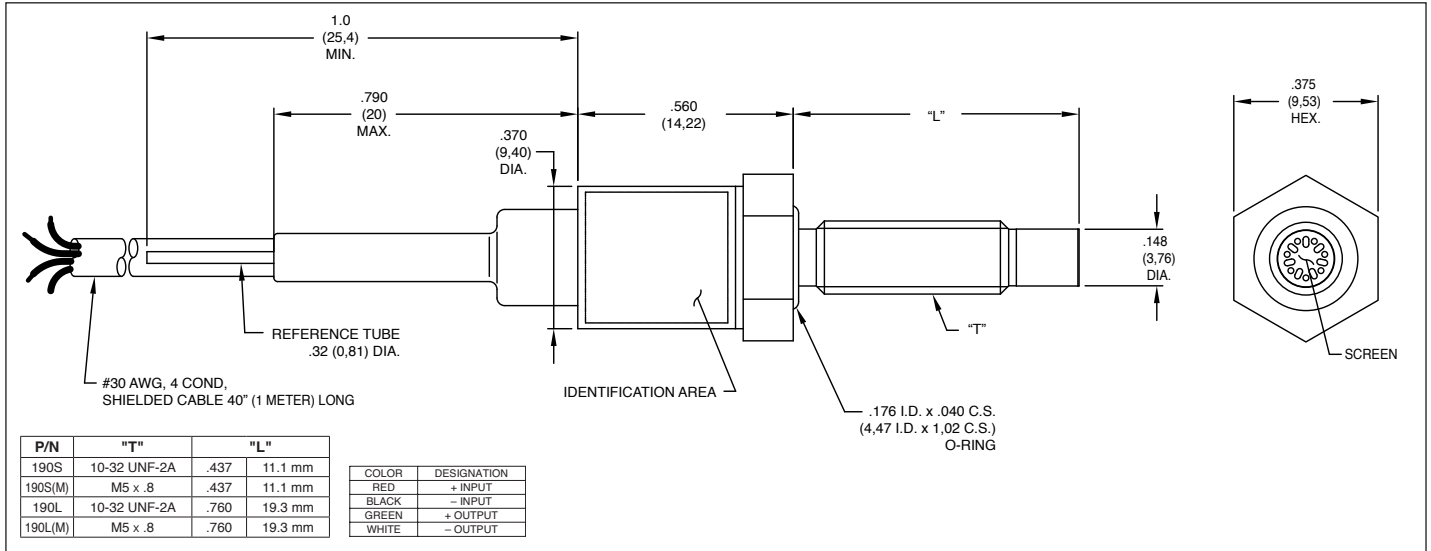

SPECIFICATIONS	
Sensitivity db Below 1 V/μ bar	-127 (Nom.)
Sensitivity mV/PSI	30.8 $\frac{mV}{PSI}$ (Nom.)
Dynamic Range	95 to 185 dB SPL
Resonant Frequency (Mechanical)	125 kHz (Nom.)
Operating Temperature Range	-65°F to 250°F (-55°C to 120°C)
Thermal Sensitivity	Less Than ± 6% of FS/100°F (0.5 db/100°F)
Excitation Voltage (DC or AC)	10V (12V Max.)
Input Impedance	1000 Ohms (Min.)
Output Impedance	1800 Ohms (Max.)
Maximum Static Pressure	5 psi (0.35 Bar) Proof and 10 psi (0.7 Bar) Burst

Sound Pressure Level Conversion Chart

SPL (db)	PSI _{RMS}	Pa _{RMS}
95	0.00016	1.12
105	0.00052	3.56
115	0.00163	11.24
125	0.00516	35.56
135	0.01631	112.4
145	0.05157	355.6
155	0.16308	1124.4
165	0.51570	3555.6
170.75	1.00000	6894.76
175	1.63079	11243.9
185	5.15701	35556.3

Formulas

$$\text{Sens [mV/PSI]} = \frac{10 \left(\frac{\text{Sens} \left[\frac{V}{\mu\text{Bar}} \right]}{20} \right)}{14.5038 \frac{\text{PSI}}{\text{BAR}}} \times 10^9$$

$$\text{Sens [db below 1V/}\mu\text{bar]} = 20 \times \log_{10} \left(\frac{\text{Sens} \left[\frac{mV}{PSI} \right]}{10^9} \times 14.5038 \frac{\text{PSI}}{\text{BAR}} \right)$$

$$\text{SPL [db]} = 20 \times \log_{10} \left(\frac{\text{Pressure [PSI]}}{2.9 \times 10^{-9}} \right)$$

Note: Custom pressure ranges, accuracies and mechanical configurations available. Dimensions are in inches. Dimensions in parenthesis are in millimeters. All dimensions nominal. (A) Continuous development and refinement of our products may result in specification changes without notice. Copyright © 2021 Kulite Semiconductor Products, Inc. All Rights Reserved. Kulite miniature pressure transducers are intended for use in test and research and development programs and are not necessarily designed to be used in production applications. For products designed to be used in production programs, please consult the factory.