



HIGH TEMPERATURE 5 VDC OUTPUT PRESSURE TRANSDUCER

ETM-HT-400-375 (M) CO SERIES

- 5 VDC Output
- 350°F Temperature Capability
- Hybrid Microelectronic Regulator-Amplifier
- Flush Diaphragm
- Silicon on Silicon Integrated Sensor **VIS**®
- All Welded Construction
- Secondary Containment On Absolute And Sealed Gage Units
- Aerospace Quality Components
- 3/8-24 UNJF or M10 X 1 Thread
- 4 Wire



ETM-HT-400-375(M) CO Series transducers are miniature, threaded flush diaphragm instruments. They utilize a flush metal diaphragm as a force collector. Force is transferred to a solid state piezoresistive sensing element via a thin intervening film of non-compressible silicone oil. This sensing sub-assembly is protected from mechanical damage by a solid screen which has been

shown to have minimal influence on the frequency response of the sensor. For applications where a true flush diaphragm is needed, Kulite will supply these transducers without the screen. Incorporation of a Kulite proprietary electronics module within the main body of this product allows for operation from an unregulated power supply of 12 ± 4 VDC or 28 ± 4 VDC. Standard output is a stable, low noise .5 to 5 VDC signal.

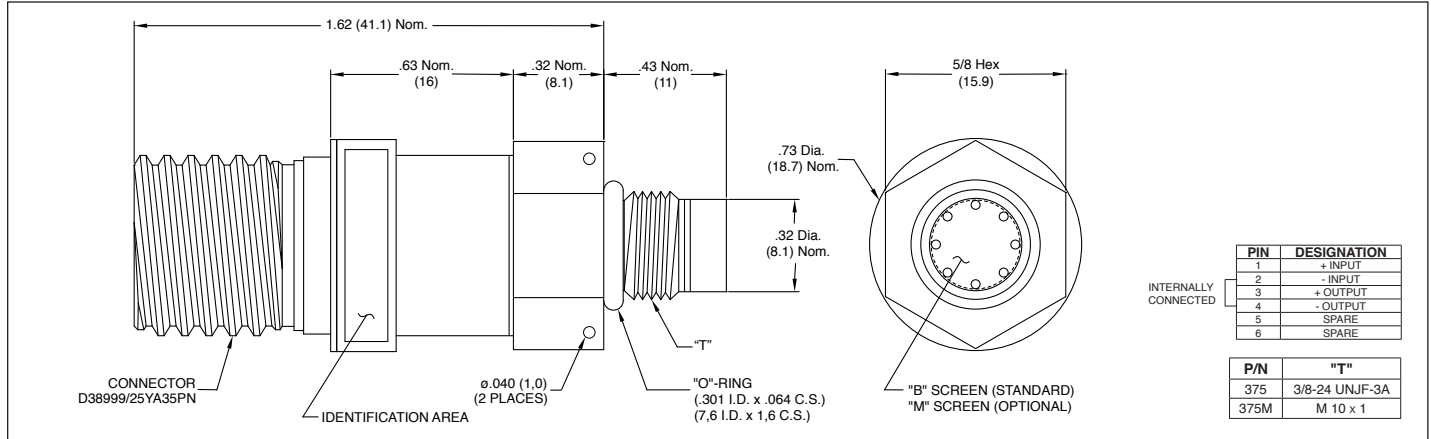

	35	70	170	350	700	1400 BAR
INPUT	Pressure Range	500	1000	2500	5000	10000 20000 PSI
	Operational Mode	Absolute, Sealed Gage				
	Over Pressure	2 Times Rated Pressure to 1000 PSI (70 BAR) 1.5 Times Rated Pressure Above 1000 PSI to a Max. of 20000 PSI (1400 BAR)				
	Burst Pressure	3 Times Rated Pressure to a Max. of 25000 PSI (1724 BAR)				
	Pressure Media	Any Liquid or Gas Compatible With 15-5 PH and 316 Stainless Steel or Inconel 625				
	Maximum Electrical Current	25 mA				
	Rated Electrical Excitation	12 ± 4 VDC or 28 ± 4 VDC				
OUTPUT	Full Scale Reading	5 VDC ± 150mV				
	Output Impedance	200 Ohms (Max.)				
	Bandwidth (-3dB)	DC to 3 KHz				
	Residual Unbalance	500 mV ± 100 mV				
	Combined Non-Linearity, Hysteresis and Repeatability	± 0.1% FSO BFSL (Typ.), ± 0.5% FSO (Max.)				
	Resolution	Infinitesimal				
	Natural Frequency of Sensor Without Screen (KHz) (Typ.)	Greater Than 400 KHz				
	Acceleration Sensitivity % FS/g Perpendicular	1.1x10 ⁻⁴	6.2x10 ⁻⁵	2.6x10 ⁻⁵	1.5x10 ⁻⁵	1.3x10 ⁻⁵ 8.0x10 ⁻⁶
	Insulation Resistance	100 Megohm Min. @ 50 VDC				
ENVIRONMENTAL	Operating Temperature Range	-65°F to +350°F (-55°C to +175°C)				
	Compensated Temperature Range	-40°F to +350°F (-40°C to +175°C) Other Ranges Quoted on Request				
	Thermal Zero Shift	± 1% FS/100° F (Typ.)				
	Thermal Sensitivity Shift	± 1% /100° F (Typ.)				
	Linear Vibration	20g Peak, Sine 10 to 2000 Hz				
	Mechanical Shock	20g Half Sine Wave 11 msec. Duration				
PHYSICAL	Electrical Connection	D38999/25YA 35PN (Mating Connector Available Upon Request)				
	Weight	24.5 Grams (Max.)				
	Pressure Sensing Principle	Fully Active Four Arm Wheatstone Bridge Dielectrically Isolated Silicon on Silicon				
	Mounting Torque	80 Inch-Pounds (Max.)				

Note: Custom pressure ranges, accuracies and mechanical configurations available. Dimensions are in inches. Dimensions in parenthesis are in millimeters. All dimensions nominal. (C) Continuous development and refinement of our products may result in specification changes without notice. Copyright © 2020 Kulite Semiconductor Products, Inc. All Rights Reserved. Kulite miniature pressure transducers are intended for use in test and research and development programs and are not necessarily designed to be used in production applications. For products designed to be used in production programs, please consult the factory.