



HIGH TEMPERATURE IS® PRESSURE TRANSDUCER

HEL-312 (M) SERIES

- Small Pressure Sensitive Area
- Patented Leadless Technology VIS®
- High Natural Frequency
- No Internal Lead Flexing
- Extra Low G Sensitivity
- -65°F To 525°F Temperature Capability

The ruggedness of this sensor has not compromised its performance. It was designed for ease of installation and will operate properly in any medium compatible with 15-5 SS or SiO₂. Coupled with high temperature, its Patented Leadless Construction makes it possible for the sensing unit to be installed in such a way that will not compromise its high natural frequency.

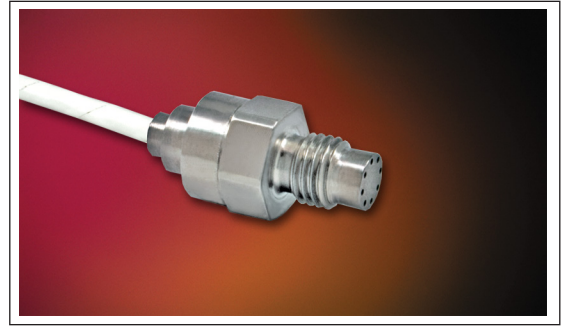

Kulite recommends the **KSC Series** of signal conditioners to maximize the measurement capability of the HEL-312 transducer.

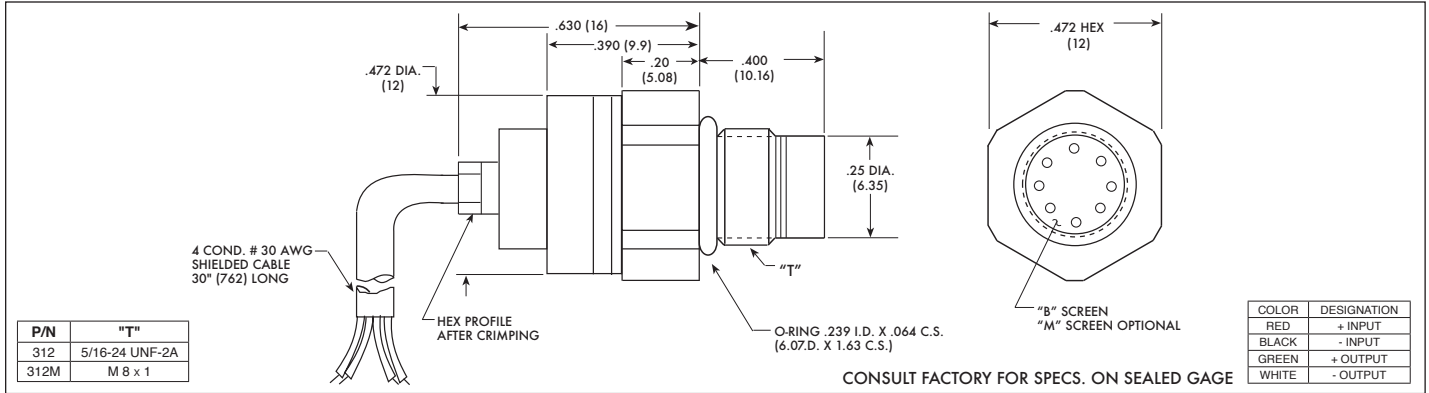

	0.7 10	1.0 15	1.7 25	3.5 50	7 100	17 250	35 500	70 1000	140 BAR 2000 PSI
INPUT									
Pressure Range									
Operational Mode	Absolute, Gage, Differential		Absolute, Gage, Sealed Gage, Differential			Absolute, Sealed Gage			
Over Pressure	2 Times Rated Pressure to 500 PSI (35 BAR), 1.5 Times Rated Pressure Above 500 PSI (35 BAR)								
Burst Pressure	3 Times Rated Pressure to a Maximum of 3000 PSI (210 BAR)								
Pressure Media	All Nonconductive, Noncorrosive Liquids or Gases (Most Conductive Liquids and Gases - Please Consult Factory)								
Rated Electrical Excitation	10 VDC/AC								
Maximum Electrical Excitation	12 VDC/AC								
Input Impedance	1000 Ohms (Min.)								
Output Impedance	1000 Ohms (Nom.)								
Full Scale Output (FSO)	100 mV (Nom.)								
Residual Unbalance	± 5 mV (Typ.)								
Combined Non-Linearity, Hysteresis and Repeatability	± 0.1% FSO BFSL (Typ.), ± 0.5% FSO (Max.)								
Resolution	Infinitesimal								
Natural Frequency of Sensor Without Screen (KHz) (Typ.)	175	200	240	300	380	550	700	1000	1400
Acceleration Sensitivity % FS/g Perpendicular	1.0x10 ⁻³	6.5x10 ⁻⁴	5.0x10 ⁻⁴	3.0x10 ⁻⁴	1.5x10 ⁻⁴	1.0x10 ⁻⁴	6.0x10 ⁻⁵	4.5x10 ⁻⁵	2.0x10 ⁻⁵
Insulation Resistance	100 Megohm Min. @ 50 VDC								
ENVIRONMENTAL									
Operating Temperature Range	-65°F to +525°F (-55°C to +273°C)								
Compensated Temperature Range	+80°F to +450°F (+25°C to +232°C)								
Thermal Zero Shift	± 1% FS/100°F (Typ.)								
Thermal Sensitivity Shift	± 1% /100°F (Typ.)								
Linear Vibration	100g Peak, Sine up to 5000 Hz								
Mechanical Shock	20,000g, 100μ sec.								
PHYSICAL									
Electrical Connection	4 Conductor 30 AWG Shielded Cable 30" Long (Optional Connector Available)								
Weight	17 Grams (Max.) Excluding Cable								
Pressure Sensing Principle	Fully Active Four Arm Wheatstone Bridge Dielectrically Isolated Silicon on Silicon Patented Leadless Technology								
Mounting Torque	50 Inch-Pounds (Max.) 6Nm								

Note: Custom pressure ranges, accuracies and mechanical configurations available. Dimensions are in inches. Dimensions in parenthesis are in millimeters. All dimensions nominal. (H) Continuous development and refinement of our products may result in specification changes without notice. Copyright © 2015 Kulite Semiconductor Products, Inc. All Rights Reserved. Kulite miniature pressure transducers are intended for use in test and research and development programs and are not necessarily designed to be used in production applications. For products designed to be used in production programs, please consult the factory.