

# ***KSIT-XXX-190***

## ***Manual***

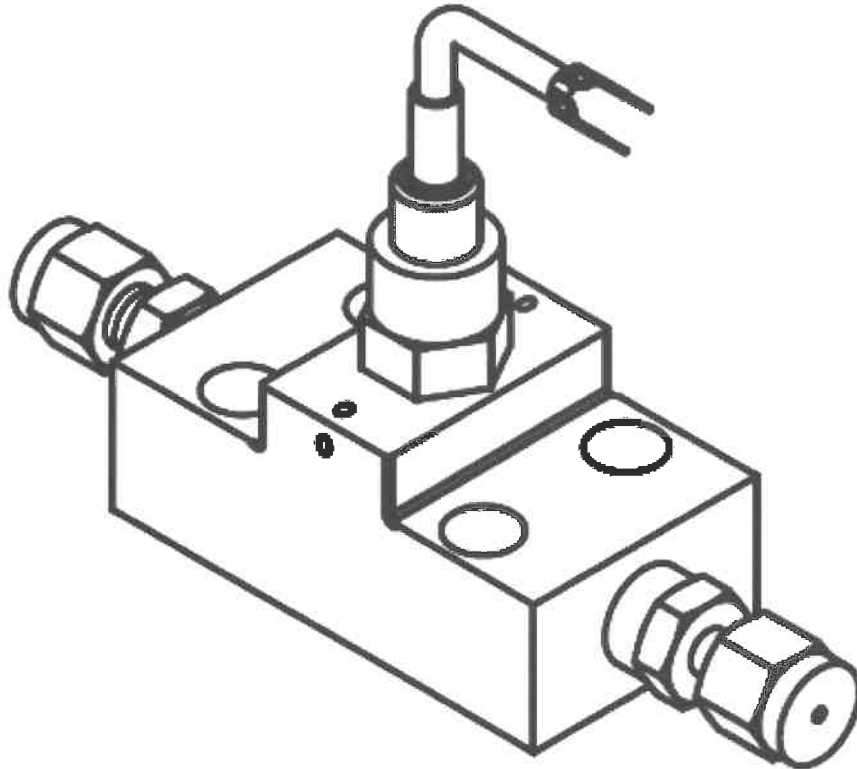

Copyright © 2022 Kulite Semiconductor Products, Inc. ("Kulite"). Proprietary. All rights reserved. This document is furnished on the express condition that neither it, nor the information it contains, may be reproduced, disclosed, or used for any purpose other than that for which it was delivered, without the express written permission of Kulite. The information subject to this restriction is contained on all pages referring to this notice.

KULITE SEMICONDUCTOR PRODUCTS INC.



Location: 1 Willow Tree Rd. Leonia, NJ 07605. US  
Phone: 201-461-0900  
Web: [www.kulite.com](http://www.kulite.com)

This document contains technical data controlled under ECCN EAR 99 of the Export Administration Regulations, administered by the United States Department of Commerce. Diversion contrary to these regulations and U.S. law is prohibited.

KM 8006  
Rev B

### KSIT Manual

**Introduction** – Semi-Infinite Tubes (SIT) were designed to help measure pressure in locations that would otherwise be damaging to current pressure sensing technologies. High temperature locations like those in turbines and combustors can easily reach temperatures which would destroy most equipment. The design of the semi-infinite tube utilizes a recess tube to locate the pressure sensor away from the high temperature media. The remote transducer location allows the transducer to be operated at close to ambient temperature. A properly-designed SIT minimizes signal attenuation and eliminates resonances / amplification in the specified frequency range. This is accomplished using the integral components of the SIT installation: the recess tube, semi-infinite tubing coil, SIT transducer port, a fitted transducer, and optionally a static pressure equalization attachment. Creating all of the components of a custom SIT accurately is difficult, especially without proper characterization and dimensional control of the included piece parts. This can lead to unpredictable and undesirable sensor performance.

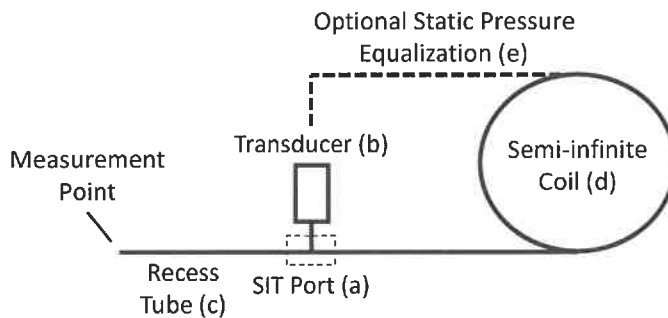

Figure 1: Traditional SIT Schematic

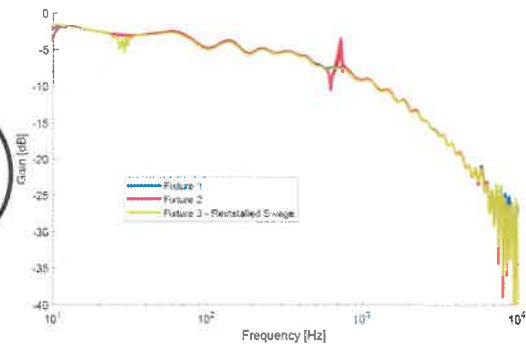

Figure 2: KSIT-040-190 Typical Response

The Kulite Semi-Infinite Tube (KSIT) has been carefully designed to be an easily-installed pressure probe solution with predictable performance for use in ultra-high-temperature locations (2000 C). The pressure ports (a) have been characterized to ensure no undesirable resonances are present as well as to ensure repeatable performance (See Figure 2 above: overlaid response of 3 different KSIT-040-190). With the option to be installed with an absolute or differential piezoresistive pressure transducer (b) the KSIT can be utilized in a variety of applications. Recess tubing (c) is easily interchangeable and replaceable by utilizing tube fitting hardware, and Kulite can offer advice on how to balance the need for temperature isolation with the signal attenuation that occurs over the tube length. Kulite can also give guidance regarding proper diameters and lengths of both recess (c) and “semi-infinite” (d) tubing. By incorporating removable parts, the KSIT can be easily removed and cleaned of any debris or moisture between test campaigns, or fitted with a moisture release trap for long-term installations. When using a differential transducer, the reference tube can be attached to the end of the semi-infinite coil for static pressure equalization (e) and higher-resolution dynamic signals.

### SIT Port (a) – Purchased from Kulite

The KSIT-XXX-190 port series has been built to mate to specific Kulite transducer designs and tubing with specific internal and outside diameters. Mating a KSIT to tubing with an incorrect diameter will result in leaks or poor performance.

Our KSIT designs are listed below:

Kulite Model Number	For Tubing Geometry (inches)	For Transducer Models
KSIT-040-190	.0625" OD., .040" ID.	XTL-190, XTEL-190, XTM-190
KSIT-055-190	.125" OD., .055" ID.	XTL-190, XTEL-190, XTM-190
KSIT-085-190	.125" OD., .085" ID.	XTL-190, XTEL-190, XTM-190

### Transducer (b) – Purchased from Kulite, Separate line item

The KSIT is designed to mate to a standard Kulite XTL, XTEL, DTL or XTM-190 transducer. These are some of the most common transducer sizes and readily available in custom pressure ranges. The KSIT can be ordered as KSIT-XXX-190(S/L/ or M) to mate to an XTL or XTEL with a matching suffix, i.e. XTL-190(S/L/ or M), depending on whether the transducer screw housing is a short ("S", or 0.473"), a long ("L", or 0.760"), an English (10-32) or Metric ("M", M5 x .8) thread. Kulite transducers are tested and mated with a specific KSIT port, and the port labeled with the transducer serial number.

### Recess Tubing (c) – Supplied by Customer

A short length of recess tubing locates the KSIT unit safely away from the hot testing environment and provides a conduit for dynamic pressures to propagate to the transducer. Narrower tube diameters will more strongly attenuate pressure signals, as will longer runs of recess tubing. See below Figure 3 for a comparison of the attenuation vs. frequency relationship for an 0.040" inner diameter SIT with three different lengths of recess tubing. Contact the factory for details and more data for other designs.

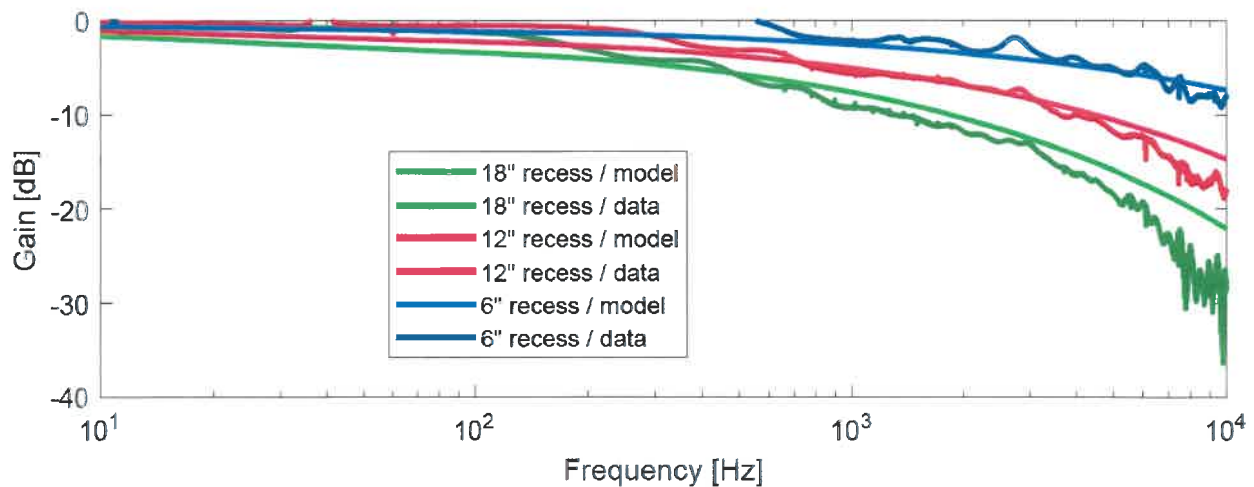

### "Semi-infinite Coil" Tubing (d) – Supplied by Customer

A longer "semi-infinite" tube is used to dampen dynamic pressures via viscous dissipation so that the dynamic pressures that pass the sensor do not reflect back, contaminating the signal. The end of the semi-infinite tube can either be capped or looped back to the reference side of a differential sensor for purely dynamic high-resolution pressure readings. The tubing must be long enough to ensure that signals do not reach the front or backside of the transducer – a good "rule of thumb" is to use a coil length of at least 2000 times the inner diameter of the tubing (for example, > 6 feet for a 0.04" ID 1/16" OD tubing). Coils can be stretched out or coiled up to a relatively tight diameter: radii of curvature of 0.5" and less have been tested and shown to produce no undesirable effects.

### Static Pressure Equalization (e) – Performed by Customer

For purely dynamic measurements, the end of the recess coil can be attached to the end of the reference tube of a differential transducer. Please note that in this case, the suggested length of semi-infinite coil tubing should be doubled. Suggested methods of connection will vary depending on expected temperature variation and static pressure requirements. Possible methods include brazing steel semi-infinite coil tubing to the reference tube, or using viton tubing as an intermediate material between the reference tube and the semi-infinite tube. Contact the factory for more details.

### Included Hardware –

- KSIT
  - KSIT Port – Main body of KSIT port featuring mounting threads for Kulite Transducer
  - Swagelok Tube Adapter – The Swagelok tube adapters have been sealed in place using either a Loctite product or Teflon tape

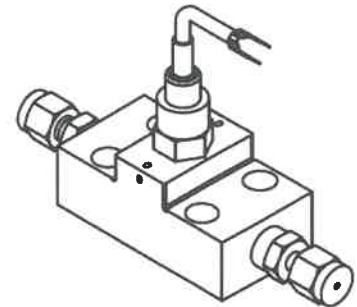

### Additional Required Hardware –

- Transducer (**purchased from Kulite**)
- Recess Tubing (**supplied by customer**)
- Dampening Tubing (**supplied by customer**)
- Mounting Hardware (Bolts/Nuts) (**supplied by customer**)

### Typical Tools Required –

- 3/8" Wrench – Sensor Installation
- 2x 5/16" Wrench – Tubing Installation
- Small Flathead Screwdriver – Sensor Wiring
- Wire Strippers – Sensor Wiring

**Installation Note** - If installed correctly there should be about an inch and a half of tubing past the top of the tightened nut of the Swagelok Part. Please see below image for reference.

**Tube Installation – See below diagram**

1. Insert tubing (red) through Swagelok components (blue, purple, and green) and make sure the tube is butting up against the flat mating section of the KSIT port (orange) before tightening the nut (blue) and ferrule (purple) with a wrench (about 1.5"). It may help to mark 1.5" from the end of the tube before installation.
2. With the tube butting against the inner flow-path, hand tighten the nut and ferrule.
3. Further tighten the nut  $\frac{3}{4}$  turns. While tightening the nut make sure to hold the Swagelok in place by using a separate wrench on the hex to prevent the part from further tightening into the fixture and possibly cracking the sealant. If you have a Swagelok gap inspection gage, the gage should not fit in-between the nut and Swagelok part body. Be careful to not overtighten the nut and ferrule, if over tightened the tube may deform and will negatively affect the pressure signal.

**Sensor Installation** – When purchased with paired transducers, each KSIT port is marked with a transducer serial number; it is recommended to install each KSIT port with its matching transducer. With O-ring in groove, thread sensor into top port and tighten to a maximum of 15 inch-lbs.

**Tube Reinstallation** - When reinstalling the tube, Swagelok recommends marking the location of the nut with a marker, and matching it upon reinstallation.

**Additional Installation Information** - For more information on Swagelok Installations please refer to pages 11-13 of the Installer's Pocket Guide for Swagelok found on [their website](#).

**Tube Mating Note** - It is recommended that each port be mated to a specific piece of tubing to ensure constant matching to the inner flow-path. Once the ferrule is tightened in place it limits the depth of the tube into the fixture. Swapping tubing or components may create inconsistencies between fixtures or mounting of the Swagelok components, which in turn may create a gap in the flow path causing undesirable performance.

